

*Department of Education and Training*

***SAFE WORKING AREAS***

***IN***

***SCHOOL  
WORKSHOPS***

*INTERIM: Advice to schools: 12 May 2003*

---

## *Safe Working Areas*

# **ASSESSMENT CONSIDERATIONS**

---

### **INITIAL ASSESSMENT**

The first significant issue to be addressed is the work space safety of a room. An analysis of the benches and machinery must be undertaken to ensure safe work areas exist throughout the workshop.

Attached is a set of guidelines to assist with this assessment. The assessment of the criteria in order of priority should be:

- 1. Enough bench space to cater for 22 students**
- 2. Benches 1200 mm apart**
- 3. Space to enter the various doorways**
- 4. Operating zones and traffic-ways as detailed in the attachment.**

It is highly likely that the outcome of this review process may require the removal of some equipment. The type of equipment to remain (if indeed this is the outcome) should be determined by the school (taking into account the condition and safety level of each piece of equipment).

## PLANNING CONSIDERATIONS

To minimise the risk of injury, it is important to ensure that machinery and work areas are laid out in a safe and useable manner. This includes allowing enough space for:

- Student circulation
- Instruction by teachers
- Machine maintenance
- Occasional larger projects

## SPACE REQUIREMENTS

### **a) Operator Positions**

- Is considered an integral part of the machine
- Minimum 600mm (mandatory) safe space for operating zone

### **b) Operator Zones**

- Minimum clearance required to another operator zone or trafficway ie no overlapping (see specific diagrams)

### **c) Trafficway Zones**

- These zones are frequently used and provide safe access between and to all operators
- 600mm mandatory minimum safe space for trafficways

### **d) Machine Zones**

- Minimum clearance (see specific diagrams) to:
  - Wall or screen (without trafficway)
  - Another machine (non operating side)
  - Fixture at 'work-plane' level

### **e) Minor Adjustment Positions**

- Indicates machine parts requiring space during adjustment or maintenance

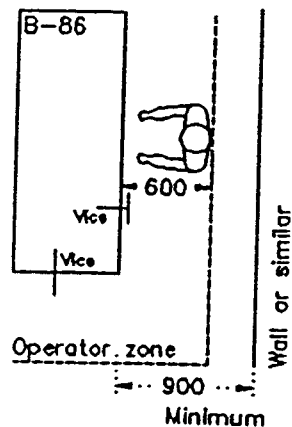
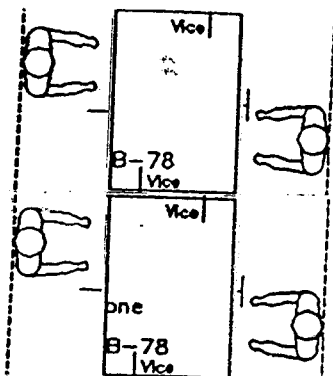
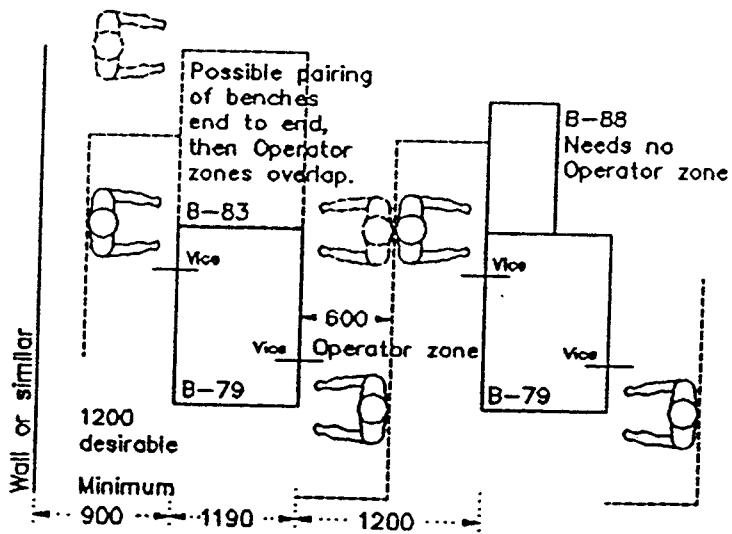
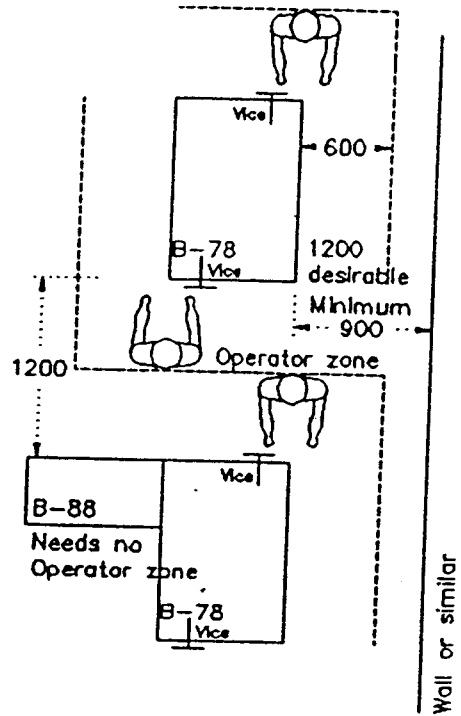

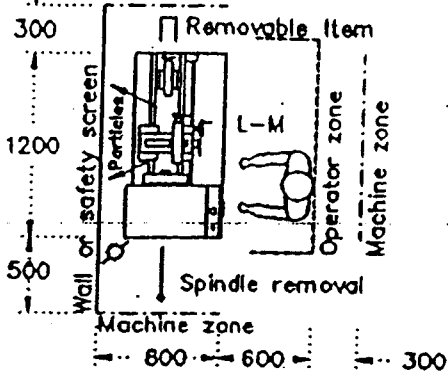

Lathe, Metal, with feed gearbox  
 (GC: 455-108253, Hercus DGM260)  
 (GC: 455-108253, Davden 260/160 GHM)

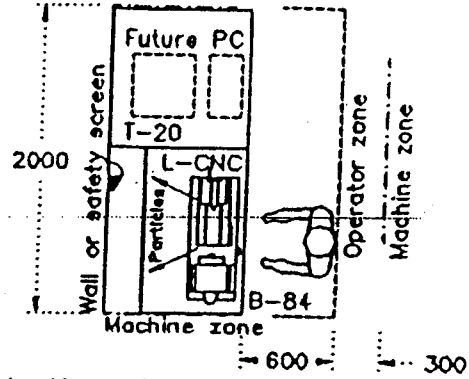

Lathe, Computer Numerical Control  
 (GC: 455-108254, Emco-Maier Compact 5PC)  
 (L-CNC NOT fixed to B-84)  
 (Tables can be 90° to each other)

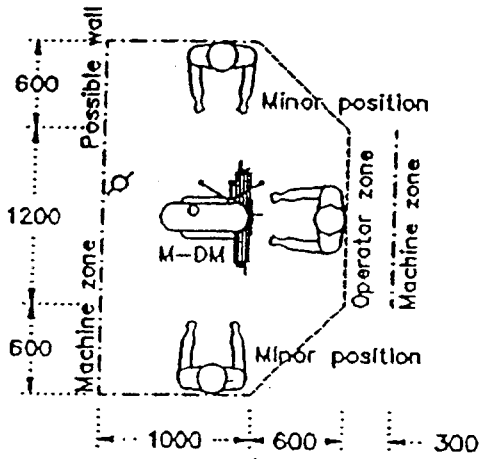

Machine, Drill/Mill  
 (GC: 455-108272, Progress CB600)

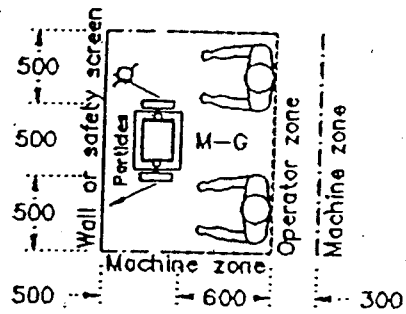

Machine, Grinder  
 (GC: 455-108276, Davden Brobo 200mm H-D)

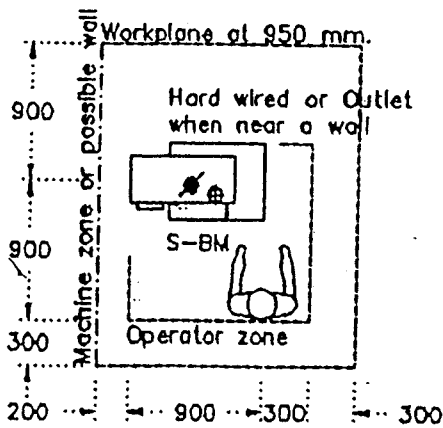

Saw, Band type, for Metal (jigsaw use)  
 (GC: 455-108274, T Jaw 360)

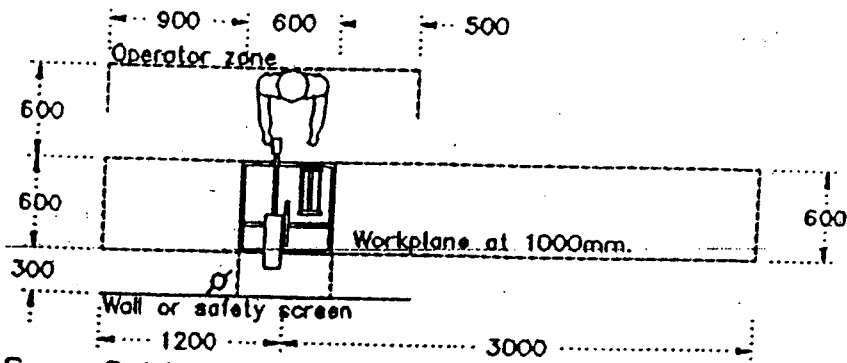

Saw, Cold Metal Cutting  
(GC: 455-108288, Davden Brobo S300C)

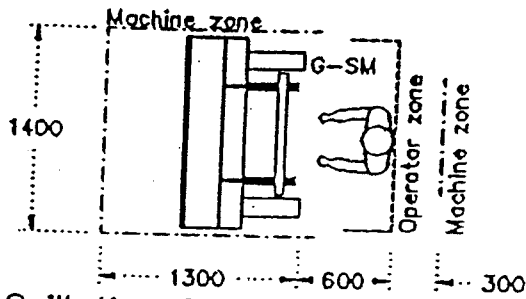

Guillotine for Sheet Metal, treadle type  
(GC: 455-108369, Epic Neatercut, non-electrical)

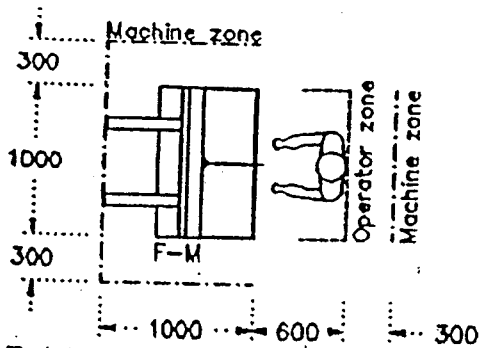

Folder, Magnetic for Sheet Metal  
(GC: 455-108429, Magnabend 1000, needs GPO only)

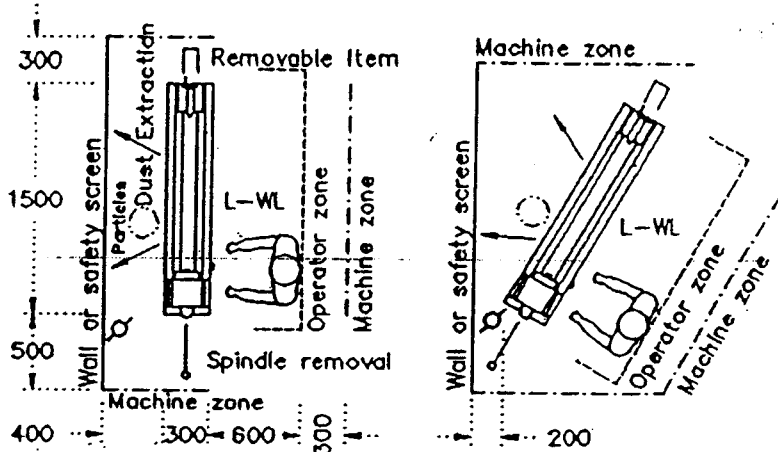

Lathe, Wood, Longbed Alternative Layout  
(GC: 455-108292, Woodfast MC 908S)

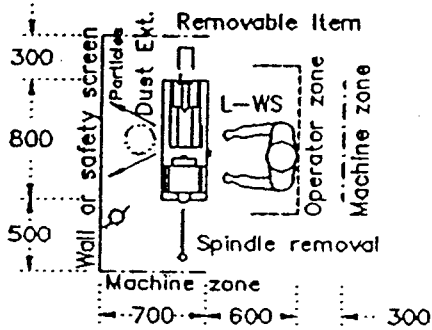

Lathe, Wood, Shortbed  
(GC: 455-108293, Woodfast MC 408S)

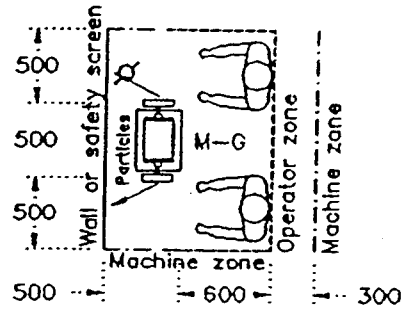

Machine, Grinder  
(GC: 455-108276, Davden Brobo 200mm H-D)

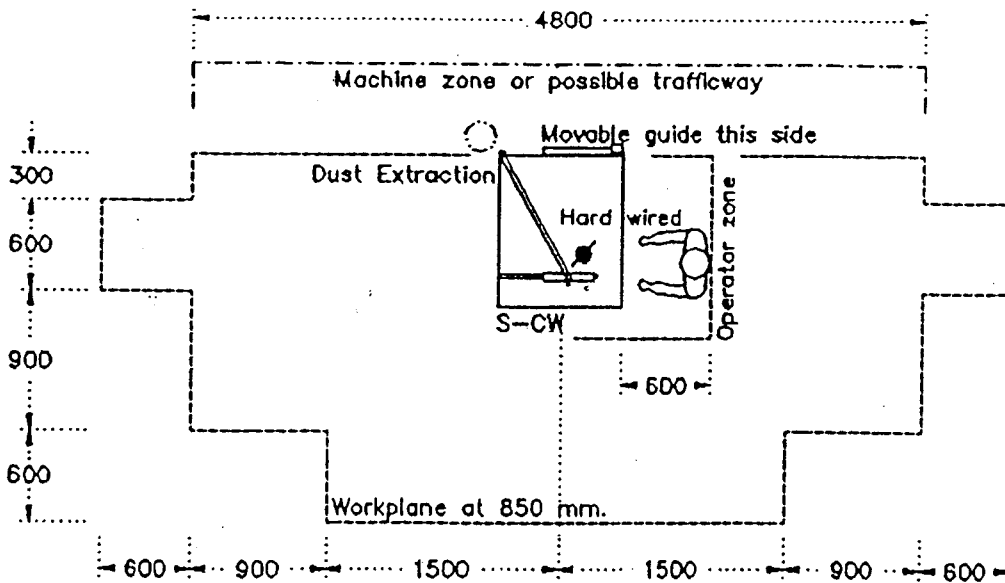

Saw, Circular for Wood  
(GC: 455-108354, Woodfast 300W)

# Safe Working Areas

# MACHINES

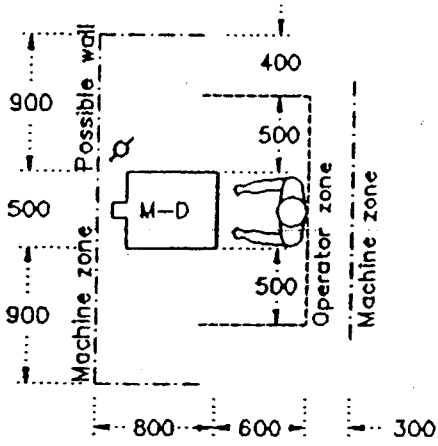

Machine, Drill  
(GC: 455-108255, Drillmor M13R)

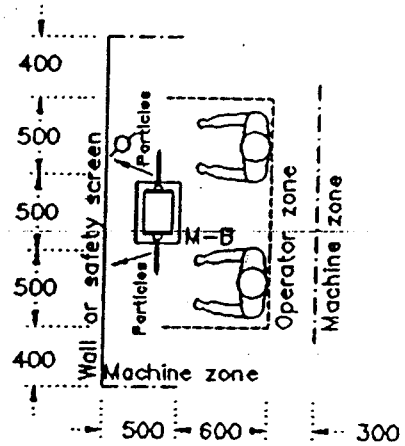

Machine, Buffing  
(GC: 455-108275, Davden Brobo 200mm H-D)

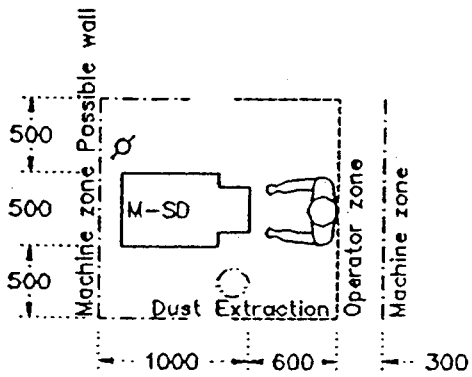

Machine, Sander, Disc type  
(GC: 455-108356, Woodfast 350)

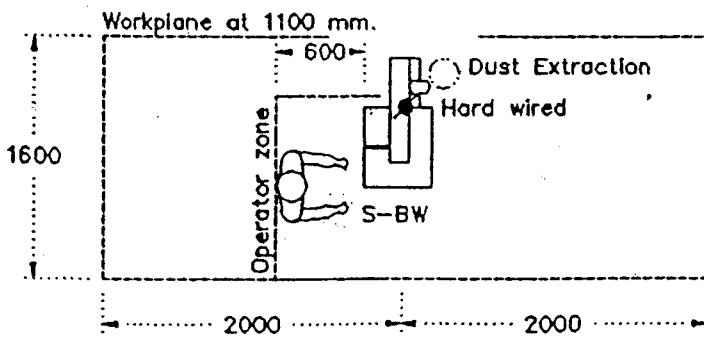

Saw, Band type, for Wood  
(GC: 455-108351, Woodfast 400)



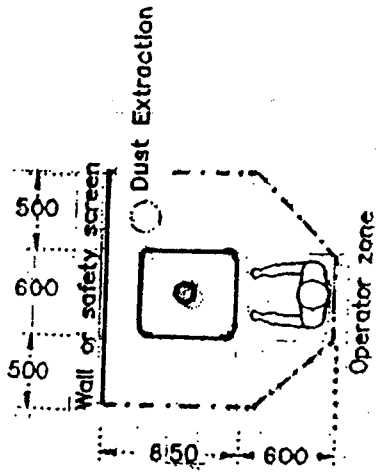

**Sander, Oscillating Vertical Spindle  
(JET - JOVS-10)**

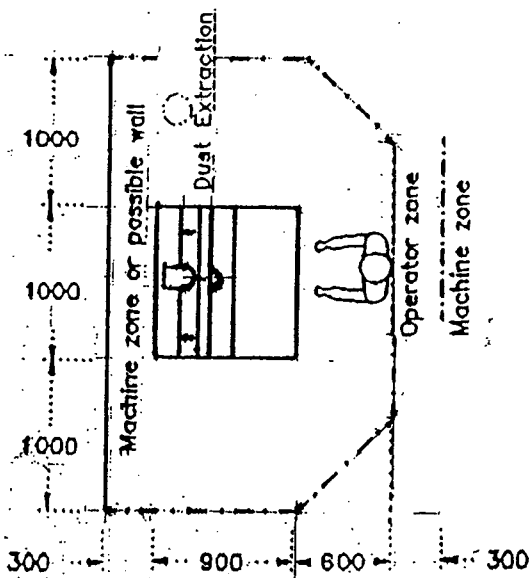

**ROUTER WORK BENCH  
(DURDEN - RT 1000)**

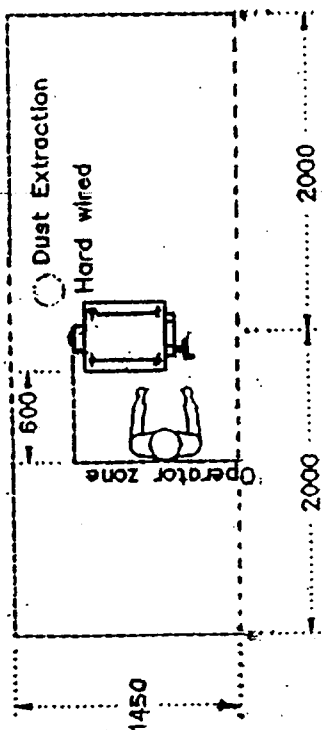

**THICKNESSER  
(WOODMASTER - CT 508)**

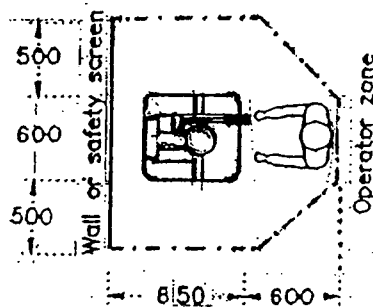

**DOWELLING and MORTISING MACHINE  
(JET -719A)**

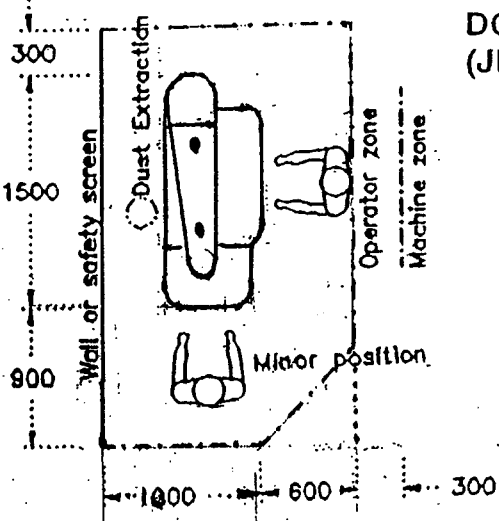

**SANDER, BELT  
(MAJOR WOODWORKING - ES-689)**

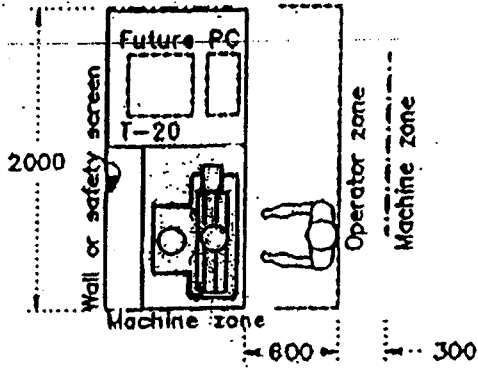

**MILLING MACHINE CNC P.C. DRIVEN**

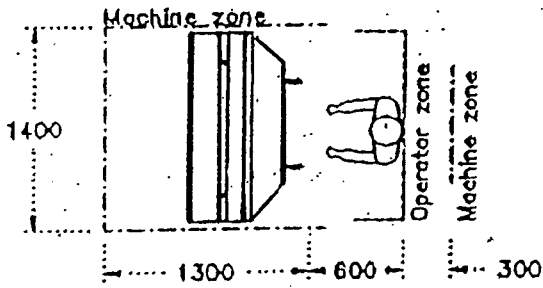

**CRAMP FOLDER and BENDER 1200 X 1.6  
(BRAMLEY 4F-F)**

# SAMPLE WORKSHOP LAYOUT – SAMPLE A (WOOD TECHNOLOGY)

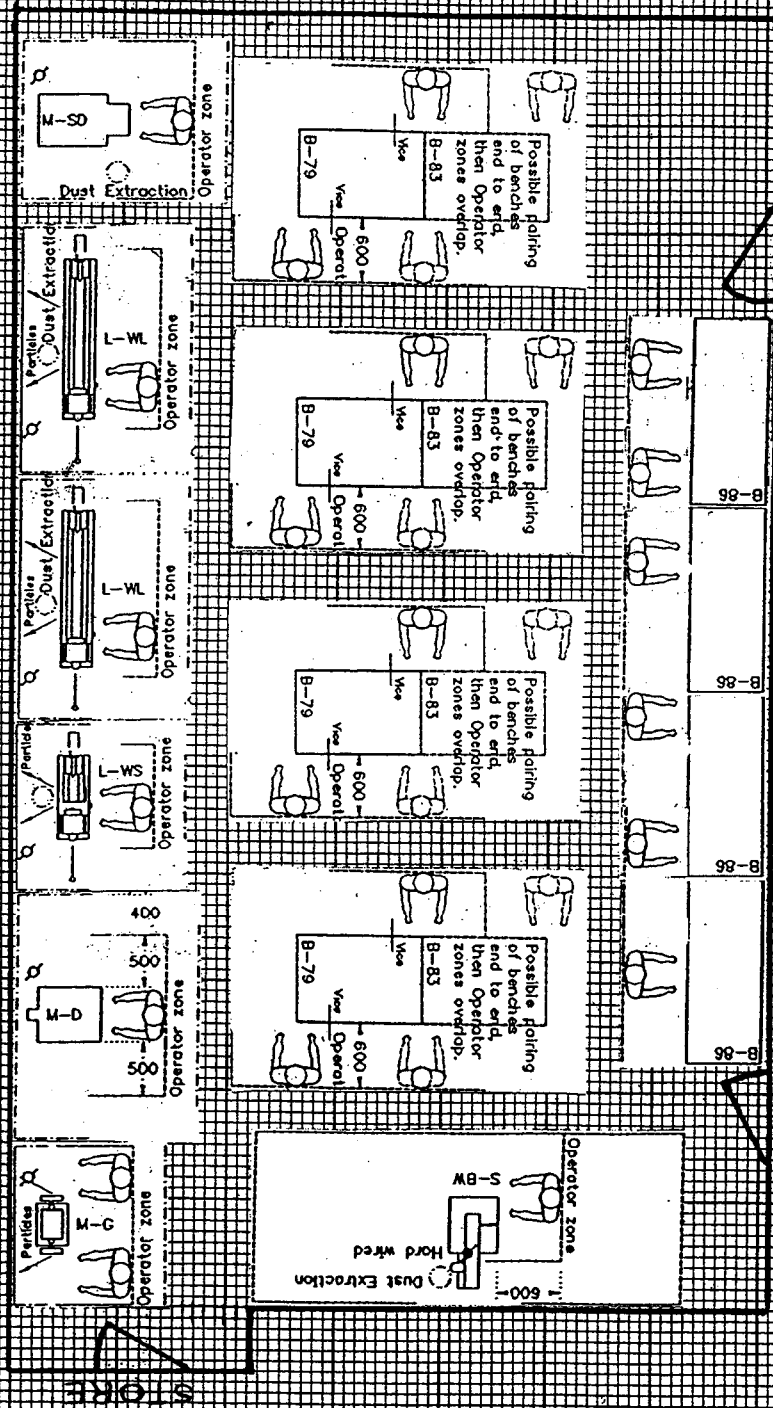

100mm grid at 150 SCALE printed on A3

# SAMPLE WORKSHOP LAYOUT – SAMPLE B (WOOD TECHNOLOGY)

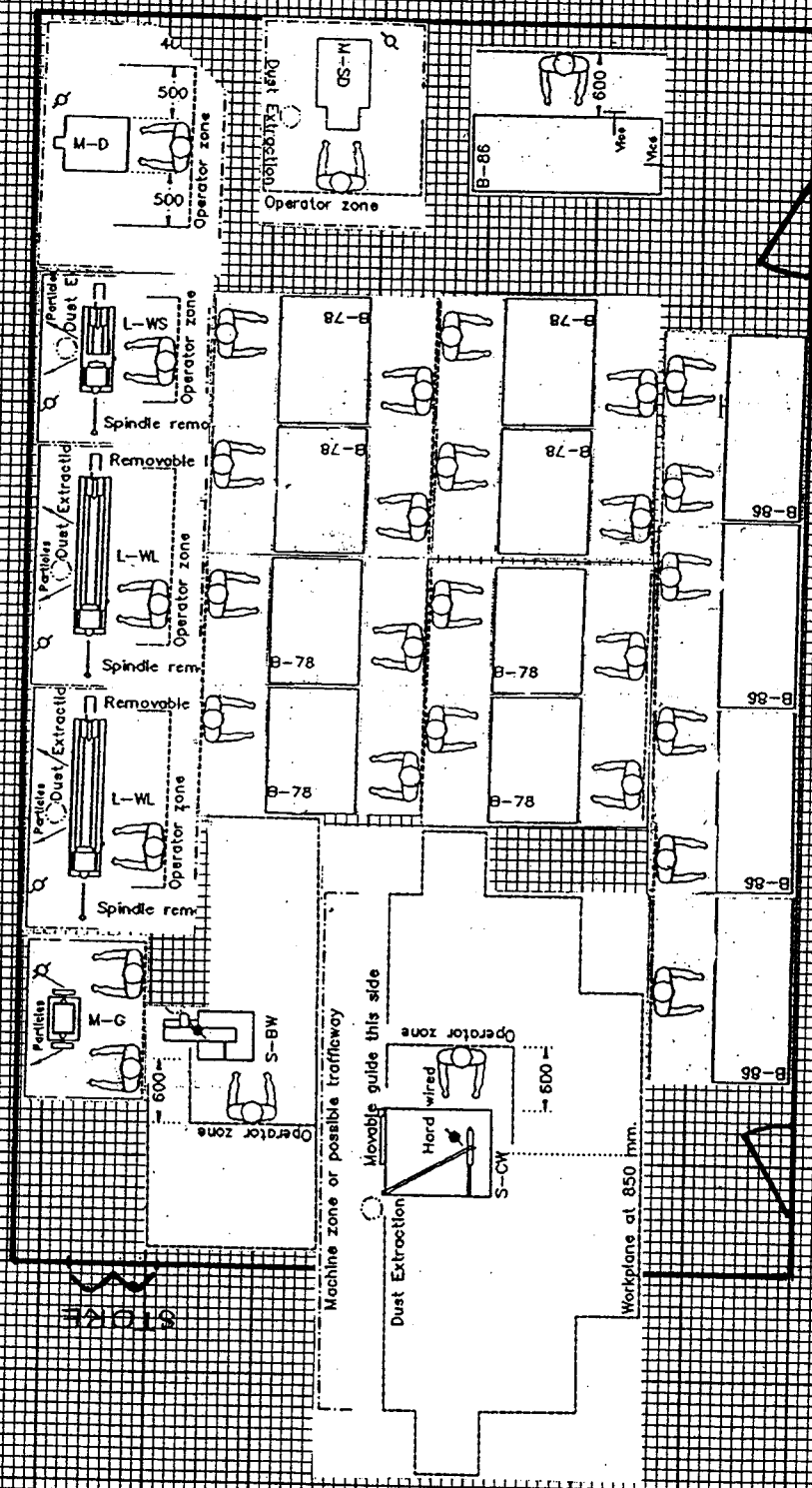

100mm grid or 1:50 SCALE printed on A3

# SAMPLE WORKSHOP LAYOUT – SAMPLE C (COMBINED WOOD/METAL TECHNOLOGY)

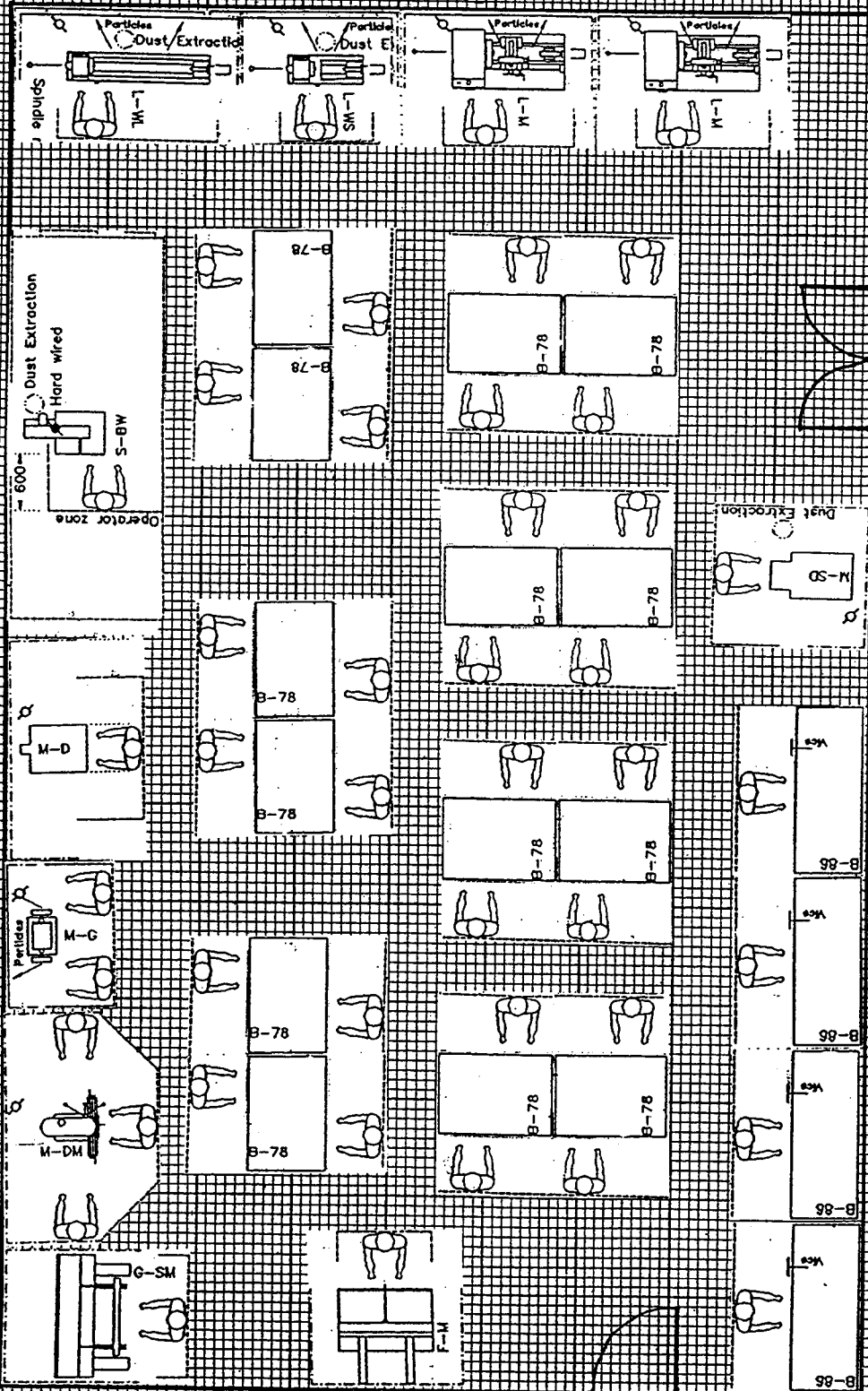

100mm @ 10.150 SCALE printed on A3